



Advanced
Control
Components
Inc.

611 INDUSTRIAL WAY WEST
EATONTOWN, N.J. 07724
PHONE: (732) 460-0212
FAX: (732) 460-0214
WWW.ADVANCED-CONTROL.COM

PRODUCT SPECIFICATION
PART NUMBER: ACSW-4443
DESCRIPTION: SWITCH, SP3T, NON-REFLECTIVE

FREQUENCY RANGE: 1.5 - 50 MHz MIN.
IMPEDANCE: 50 OHMS
RF INPUT LEVEL: 0 dBm
VSWR: 2.0 : 1 MAX.
INSERTION LOSS: 2.0 dB MAX.
NOISE FIGURE: 3.0 dB MAX.
ISOLATION: 50 dB MIN.
SWITCHING SPEED: 300 uSEC. MAX.
SWITCHING TRANSIENTS: -90 dBm MAX.
IP3 OUT: +34 dBm MIN.
IP2 OUT: +65 dBm MIN.
RF CONNECTORS: SMA FEMALE
BIAS AND CONTROL: $\varnothing 0.02$ " SOLDER PIN
FINISH: GRAY EPOXY PAINT PER MIL-C-22750

REV.	DESCRIPTION	DATE	APP'D
-	INITIAL RELEASE	2/14/01	CP
A	UPDATED SPECS.		

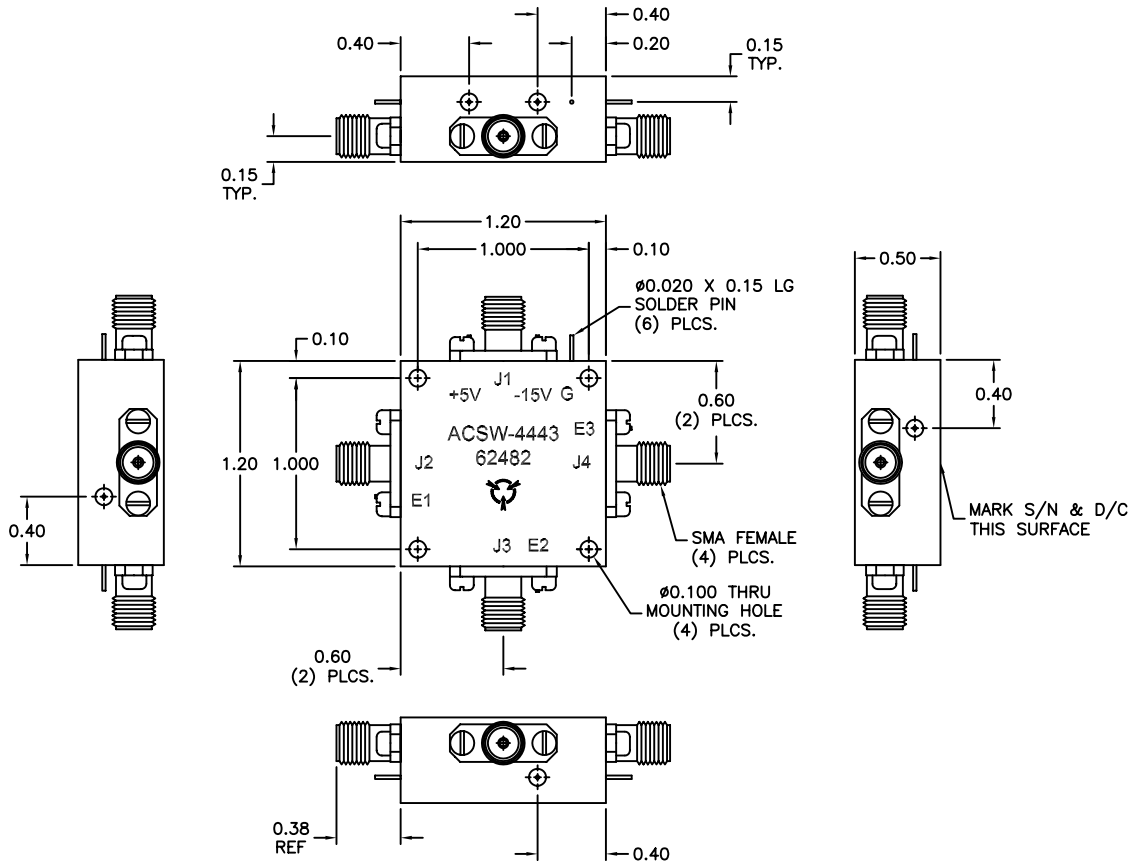

This document is the property of Advanced Control Components Inc. and contains company confidential and/or proprietary information. It is issued in strict confidence and the recipient shall not reproduce, copy, cause to be reproduced or copied, disclose to others, or use as the basis for manufacture, sale or purchase of apparatus the contents or portions thereof of this document without written permission of Advanced Control Components Inc.

CAUTION
UNLESS THIS DRAWING BEARS AUTHORIZED SIGNED APPROVAL(S) IT IS PRELIMINARY AND IS NOT TO BE USED FOR MANUFACTURING PURPOSES.

UNLESS OTHERWISE SPECIFIED

DIMENSIONS ARE IN INCHES
TOLERANCES ON FINISH: RMS 63
ANGLES: $\pm 1/2^\circ$ FRACTIONS: $\pm 1/64$
4 PLACE DECIMALS: ± 0.0005
3 PLACE DECIMALS: ± 0.005
2 PLACE DECIMALS: ± 0.1

DRAWN BY: C PERRONE 2/14/01

APPROVED BY: D. WHEAT 2/14/01

SHEET: 1 OF 1

FILECODE: ACSW-4443